

Hardware Specifications

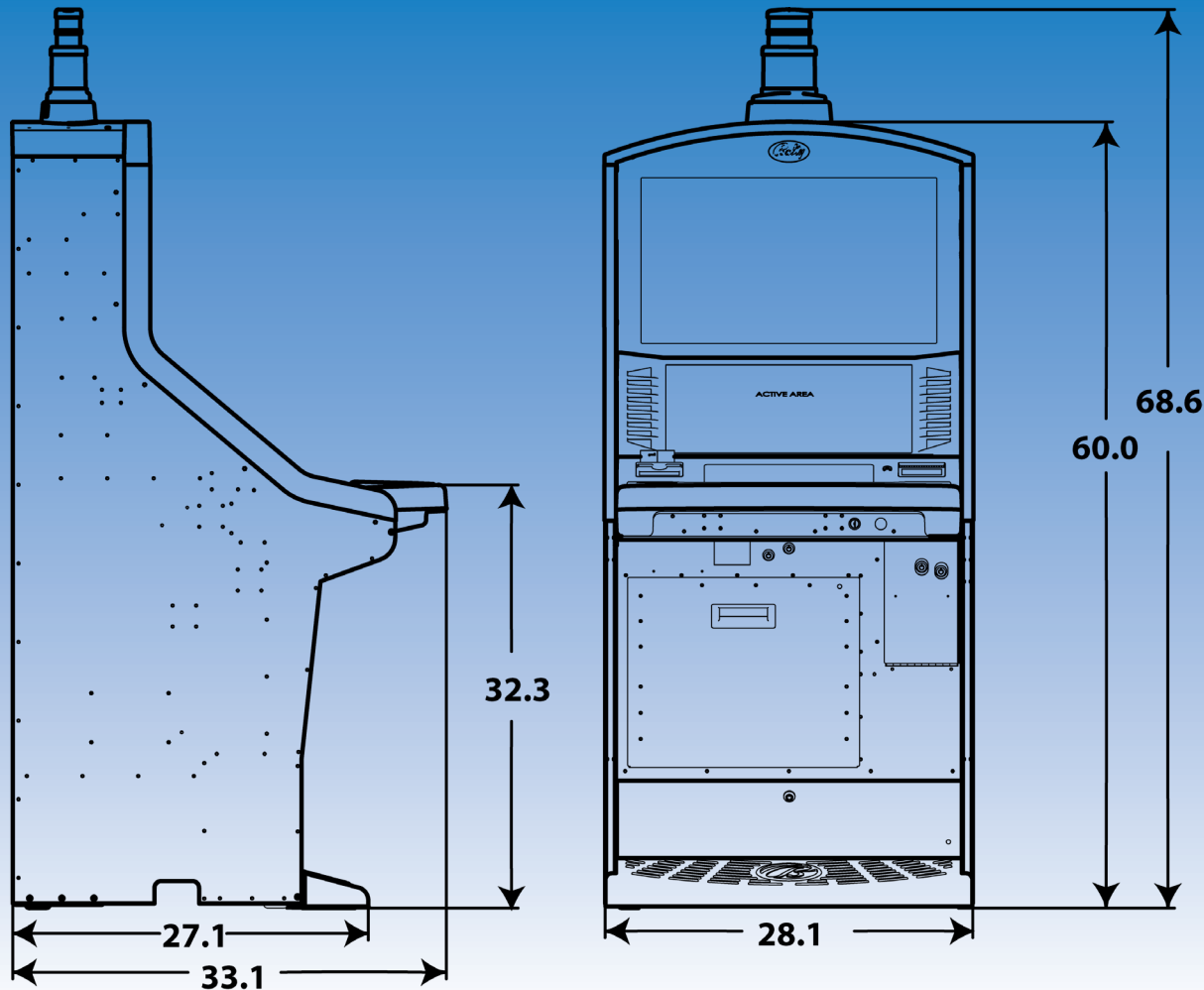

The **ALPHA Pro Slant V22/26** video cabinet brings wide-screen high-definition video in a reduced height cabinet that preserves casino sight-lines. Padded armrests and advanced ergonomic design creates a *Comfort Zone™* for increased time on device.

- Elimination of game glass simplifies game conversions.
- Complete download platform when configured with the programmable button panel.
- Cup holders and padded armrest allows for extended periods of play with maximum comfort.
- Ergonomically located space for player tracking systems above the button deck.
- Digital Signal Processing sound system custom designed for the modern gaming environment and located to the sides of the display to produce a cinematic surround-sound audio effect.
- Uses Bally's ALPHA OS™ with its user-friendly interface.
- High definition wide screen 22" touch screen game display with 26" high-definition wide screen secondary display.
- Super Candle adds eye-catching LED color display to increase player attraction.

Alpha Pro™ Slant V22/26

Specifications

BILL ACCEPTORS	JCM® WBA®/UBA™, MEI Cashflow™ Ardac, Cash Code,
BILL ACCEPTOR BEZEL OPTIONS	LED Bezel (standard), Sentry™
BILL ACCEPTOR CASHBOX OPTIONS	Metal, Plastic, JCM ICB, JCM 1,000 note, MEI Easitrax, MEI 1,000 note

TICKET PRINTERS	Ithaca® 950, FutureLogic Gen2™
COIN ACCEPTORS	Not available
HOPPERS	Not available

PROGRESSIVE SUPPORT	Internal, Linked (onscreen display)
----------------------------	-------------------------------------

BUTTON PANELS SUPPORTED*	
8 Button, 10 Button, 14 button, 16 button, Unibutton, Programmable button	

CUSHIONED FRONT BUMPER	
Extended/Ergonomic	

FOOTREST	Standard, Sled
-----------------	----------------

TOPPERS*	360 degree
-----------------	------------

SAS VERSIONS SUPPORTED	
SAS 6.01 with AFT, Promotional Credits, Earlier SAS versions also supported.	

SCREEN	Game Display: 22.0" diagonal Secondary Display: 26" diagonal
---------------	-----------------------------------------------------------------

SCREEN RESOLUTION	1360 × 768 pixels
--------------------------	-------------------

RECOMMENDED SEAT HEIGHT	19.5"
--------------------------------	-------

RECOMMENDED STAND HEIGHT	
No stand required	

CABINET	
Weight:	336 lbs (152.7 kg)
Height with Super Candle:	68.6" (1742 mm)
Height with Standard Tower Light:	65.0" (1651 mm)
Height without Tower Light:	60.0" (1524 mm)
Width:	28.1" (714 mm)
Depth:	33.1" (841 mm)

POWER SUPPORTED	110 volts, 220 volts
Startup/Surge State:	4.8 A
Operating State:	2.1 A
Max Load:	6.3 A
Power Consumption:	832 BTU/hr
<i>Typical currents are provided for reference only. Actual current use will depend upon machine configuration and addition of supplemental equipment such as, but not limited to, systems monitoring equipment, progressive equipment, and service equipment.</i>	

SAFETY RATINGS	UL, CSA, CE, FCC
-----------------------	------------------

FINISHES AND LAMINATES	
Chrome or Gold trim on Black, Custom laminate	

TOWER LIGHTS	2 Tier, 3 Tier, 4 Tier, Super Candle
---------------------	--------------------------------------

LOCKS	
Deck lid, Drop door, Cash box door, Cash box, CPU, Compact-Flash® card, Bottom door. All lock openings are 5/8" x 3/4". Locks 1 1/8" long can be used with spacers to maintain the 1/2" lock length. Dual locks are optional.	

*game dependent



www.BallyTech.com

Alpha Pro Slant HW Spec Sheet 1109v3.0

6601 S. Bermuda Road
Las Vegas, NV 89119
(702) 584-7700 Phone
(702) 584-7770 Fax

©2009 Bally Gaming, Inc.